

Hublot rectangulaire forme oblongue Référence HRLB

Fiche technique 01/02/2024

◆ Utilisation :

Observation de l'intérieur de réservoirs, cuves, silos, etc... Particulièrement indiqué pour le contrôle de niveau de liquides.

◆ Conditions de service :

Pression : 2,5 / 6 / 10 / 25 bar ou vide
Avant la pose du hublot, vérifier le renforcement de la découpe en fonction de la paroi de cuve conformément à AD-Merkblatt.

◆ Température de service :

100°C avec verre au silicate de soude
243°C avec verre au silicate de bore
Ces températures se réfèrent à des verres non protégés (par du mica).

◆ Certificats matière/ Réception :

Sur demande, les certificats et les tests peuvent être fournis selon DIN EN 10204 3.1/3.2.

◆ Nomenclature et choix des matières :

1. Cadre inférieure à souder :
Inox 1.4404 ou autre
Acier S235JR+N (RSt 37-2) ou autre
2. Joints :
KLINGERSil C-4400, Néoprène, PTFE ou autre
3. Vitre :
* Verre sodocalcique trempé T° 100°C
* Verre au silicate de bore T° 243°C
4. Cadre supérieur
Inox 1.4404 ou autre (ex: acier S235JR+N (RSt 37-2))
5. Vis d'assemblage Inox A4 ou Acier 8.8

◆ Usinage :

Usinage de rayon sur le cadre inférieur au niveau des arêtes pour les revêtements (ébonitage).
Pour une soudure sur virole, l'usinage d'un rayon suivant vos spécifications.

◆ Montage :

Avant le montage de la vitre, vérifier l'absence de déformations et la planéité de la portée de joint.
Déformations et défauts de planéité conduisent à des problèmes d'étanchéité voire même à la rupture de la vitre.

Le serrage des vis d'assemblage débute au milieu du hublot puis en croix, il doit être progressif et homogène.



Hublot rectangulaire oblong

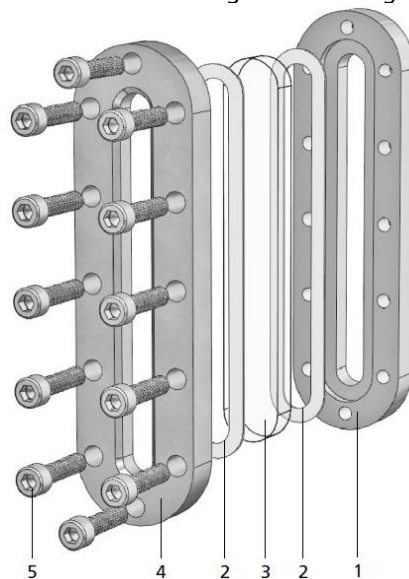

Hublot rectangulaire oblong - Vue éclatée

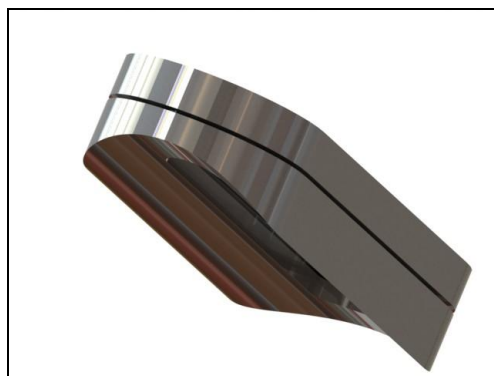

Hublot oblong avec usinage d'un rayon

Dimensions des hublots rectangulaires oblongs

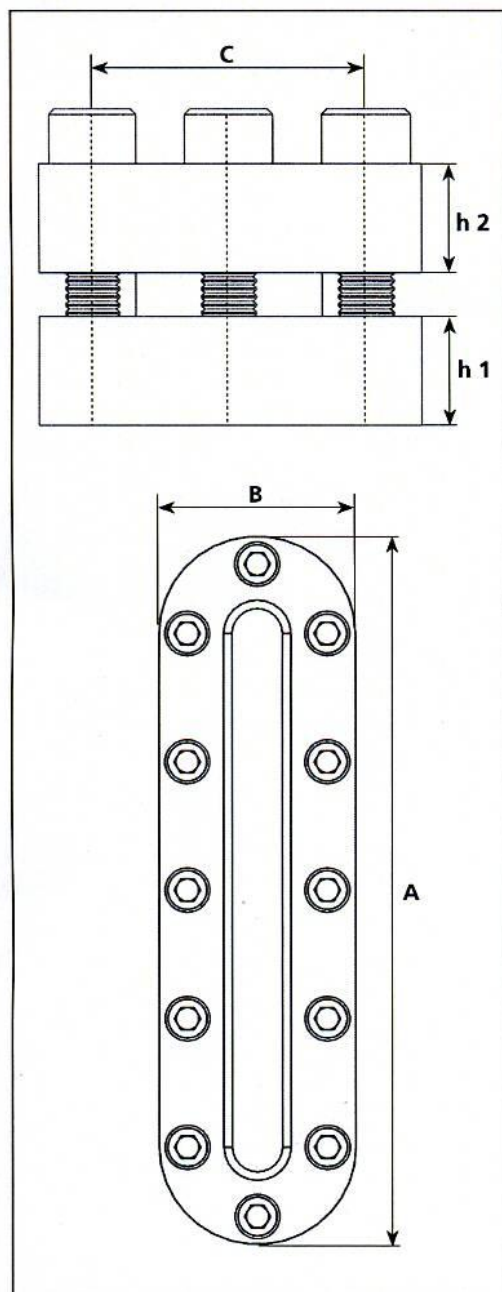

taille	PN	Dimensions		Visibilité		Vis M10		Dimensions verre	Ep. bride		Poids Kg
		A	B	long	larg	nbr	C		h1	h2	
1	2,5	266	116	200	50	8	94	70/10x220	25	15	6,3
2	2,5	341	116	275	50	10	94	70/10x295	25	15	7,6
3	2,5	416	116	350	50	12	94	70/10x370	25	15	9,8
4	2,5	491	116	425	50	14	94	70/10x445	25	15	11,0
5	2,5	566	116	500	50	16	94	70/10x520	25	15	12,3
6	2,5	641	116	575	50	18	94	70/10x595	25	15	14,2
7	2,5	791	116	725	50	22	94	70/10x745	25	15	18,0
<hr/>											
1	6	261	96	195	30	10	74	50/10x215	25	15	5,6
2	6	316	96	250	30	12	74	50/10x270	25	15	7,0
3	6	371	96	305	30	14	74	50/10x325	25	15	8,0
4	6	426	96	360	30	16	74	50/10x380	25	15	8,9
5	6	481	96	415	30	18	74	50/10x435	25	15	10,0
6	6	536	96	470	30	20	74	50/10x490	25	15	12,0
7	6	646	96	580	30	24	74	50/10x600	25	15	13,7
<hr/>											
1	10	260	80	198	18	12	58	35/17x220	25	15	5
2	10	305	80	243	18	14	58	35/17x280	25	15	5,8
3	10	350	80	288	18	16	58	35/17x320	25	15	6,5
4	10	395	80	333	18	18	58	35/17x370	25	15	7,5
5	10	440	80	378	18	20	58	35/17x395	25	15	8
6	10	485	80	423	18	22	58	35/17x440	25	15	9,5
7	10	575	80	513	18	26	58	35/17x530	25	15	13,0
<hr/>											
1	25	186	80	121	15	10	58	34/17x140	25	20	4,0
2	25	211	80	146	15	10	58	34/17x165	25	20	4,5
3	25	236	80	171	15	12	58	34/17x190	25	20	5,0
4	25	296	80	231	15	14	58	34/17x250	25	20	6,0
5	25	326	80	261	15	16	58	34/17x280	25	20	6,8
6	25	366	80	301	15	18	58	34/17x320	25	20	7,5
7	25	386	80	321	15	18	58	34/17x340	25	20	8,0

Référence des hublots : HRLB / PN / taille / A pour acier et I pour inox

Exemple pour un hublot rectangulaire oblong en inox taille 1 PN2,5 :

HRLB/2/1/I

Exemple pour un hublot rectangulaire oblong en acier taille 6 PN10 :

HRLB/10/6/A

Nous consulter pour toutes dimensions spéciales.

Lumiglas Oblong Oval Sight Glass Fitting

Suitable for welding into or onto vessel walls, this sight glass fitting comes complete with an oblong oval glass plate sealed by gaskets inserted on either side of it and bolted firmly in place.

• Application:

Ideal for viewing the insides of pipes, vessels, containers, reactors, silos, etc., and used primarily as a liquid level indicator for monitoring e. g. filling levels.

• Operating conditions:

- Pressure 2.5/6/10/25 bar
- Vacuum
- Prior to using the fitting, the cut-out reinforcement together with the relevant material of the vessel should be checked in accordance with AD-Merkblatt.

• Operating temperature:

- 100°C when using soda-lime glass to DIN 8903 (on request only)
- 243°C when using borosilicate glass to DIN 7081

These temperatures refer to unprotected glass, i. e. without a protective layer of mica).

• Certification/Approval:

Testing and certification can be provided to DIN EN 10204 3.1/3.2 as required by the customer (at extra charge).

• Components and alternative materials:

in nebenstehender Ansicht sind:

Item	Component	Material options
1	Base frame	Stainless steel 1.4404 or other grades on request (Steel S235JR+N (RST 37-2))
2	Gaskets	KLINGERSil C-4400; Neoprene; PTFE or others
3	Sight glass plate	- Soda-lime glass: thermally prestressed to DIN 8903, max. operating temperature: 100°C - Borosilicate glass: thermally prestressed to DIN 7081, max. operating temperature: 243°C
4	Cover frame	Stainless steel 1.4404 or other grades on request (Steel S235JR+N (RST 37-2))
5	Fastening bolts	Steel 8.8 or stainless steel A4

• Assembly:

Prior to fitting the glass plate, check to ensure that the base frame (1) is free of any distortion and the sealing surface is flat. Any tension or unevenness can lead to leakage or may even cause the sight glass to break.

After the base frame has been welded into or onto the pipe or vessel wall, the gaskets (2), the sight glass plate (3) and the cover flange (4) are positioned in the order illustrated and then fastened to the base frame (1) with the bolts (5).

When securing the cover flange, the bolts should be tightened with a uniform torque, starting with the bolts in the middle and working crosswise towards the ends, i.e. in an alternating sequence.



Complete assembly of a Lumiglas oblong oval sight glass fitting

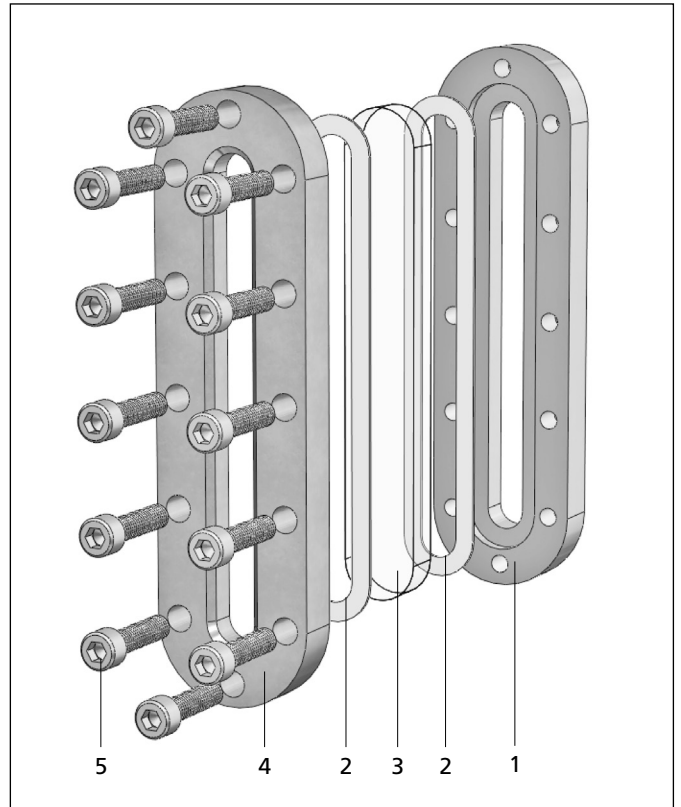

Exploded view of a Lumiglas oblong oval sight glass fitting

• Dimensions of a Lumiglas oblong oval sight glass fitting:

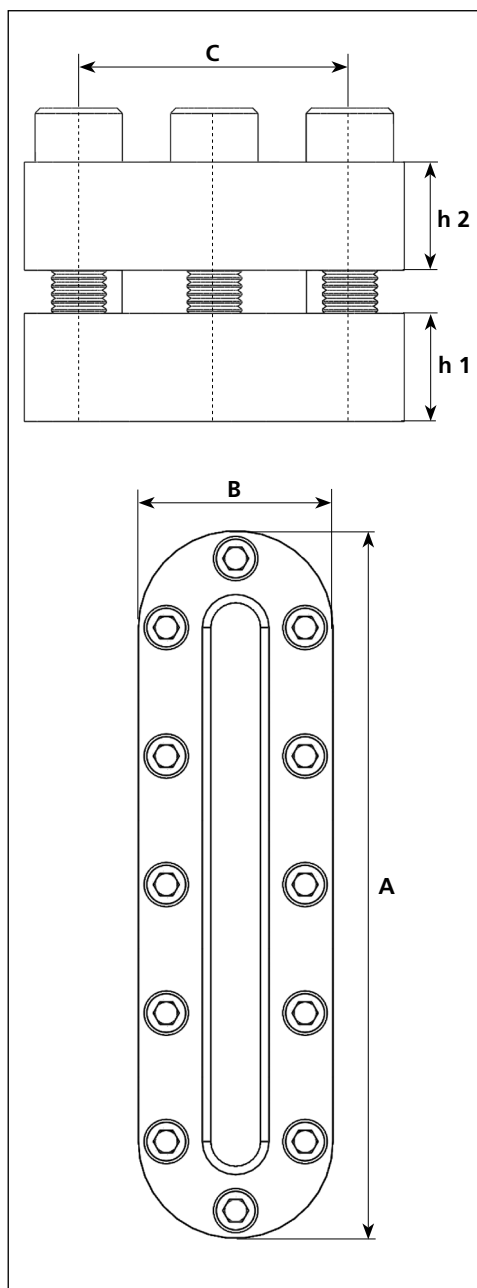

Size	Nominal pressure	Installation dimensions		Viewing Width		M10 bolts		Glass dimensions	Flange thickness		Weight kg
	PN	A	B	Length	Width	Pcs.	C		h 1	h 2	
1	2.5	266	116	200	50	8	94	70/10x220	25	15	6.3
2	2.5	341	116	275	50	10	94	70/10x295	25	15	7.6
3	2.5	416	116	350	50	12	94	70/10x370	25	15	9.8
4	2.5	491	116	425	50	14	94	70/10x445	25	15	11.0
5	2.5	566	116	500	50	16	94	70/10x520	25	15	12.3
6	2.5	641	116	575	50	18	94	70/10x595	25	15	14.2
8	2.5	791	116	725	50	22	94	70/10x745	25	15	18.0
1	6	261	96	195	30	10	74	50/10x215	25	15	5.6
2	6	316	96	250	30	12	74	50/10x270	25	15	7.0
3	6	371	96	305	30	14	74	50/10x325	25	15	8.0
4	6	426	96	360	30	16	74	50/10x380	25	15	8.9
5	6	481	96	415	30	18	74	50/10x435	25	15	10.0
6	6	536	96	470	30	20	74	50/10x490	25	15	12.0
8	6	646	96	580	30	24	74	50/10x600	25	15	13.7
1	10	260	80	198	18	12	58	35/10x215	25	15	5.0
2	10	305	80	243	18	14	58	35/10x260	25	15	5.8
3	10	350	80	288	18	16	58	35/10x305	25	15	6.5
4	10	395	80	333	18	18	58	35/10x350	25	15	7.5
5	10	440	80	378	18	20	58	35/10x395	25	15	8.0
6	10	485	80	423	18	22	58	35/10x440	25	15	9.5
8	10	575	80	513	18	26	58	35/10x530	25	15	13.0
1	25	186	80	121	15	10	58	34/17x140	25	20	4.0
2	25	211	80	146	15	10	58	34/17x165	25	20	4.5
3	25	236	80	171	15	12	58	34/17x190	25	20	5.0
4	25	296	80	231	15	14	58	34/17x250	25	20	6.0
5	25	326	80	261	15	16	58	34/17x280	25	20	6.8
6	25	366	80	301	15	18	58	34/17x320	25	20	7.5
8	25	386	80	321	15	18	58	34/17x340	25	20	8.0

• Externally mounted liquid level indicator:

Lumiglas oblong oval sight glass fittings are also available with a closed base frame for use as an external liquid level indicator. In this case, the indicator is fed via pipes that run through holes in the base frame plate. The base frame is provided with the relevant drilled or tapped holes for this purpose.

• Order data:

Lumiglas Oblong oval sight glass fitting
 Nominal pressure:...
 Size:... Length:...
 Material: Base frame:... Cover frame:...
 Sight glass plate:... Gaskets:...
 (Inspection certificates 3.1/3.2 can be provided on request.)